

A Survey of Mobility Management in Next-Gen All-IP- Based Wireless Systems

**IAN F. AKYILDIZ, JIANG XIE, AND SHANTIDEV MOHANTY
GEORGIA INSTITUTE OF TECHNOLOGY**

Introduction

- Next-Gen wireless systems will contain heterogeneous access technologies.
 - WLAN, cellular, satellite, etc.
 - Varying coverage, data-rates, architectures, service demands.
- Mobility Management is a problem area that will influence the viability of wireless systems.
 - Location Management
 - Handoff Management
 - Can be solved at the network layer, link layer, or cross layer.

Network Layer (Layer 3) Solutions

Macro & Micro Mobility

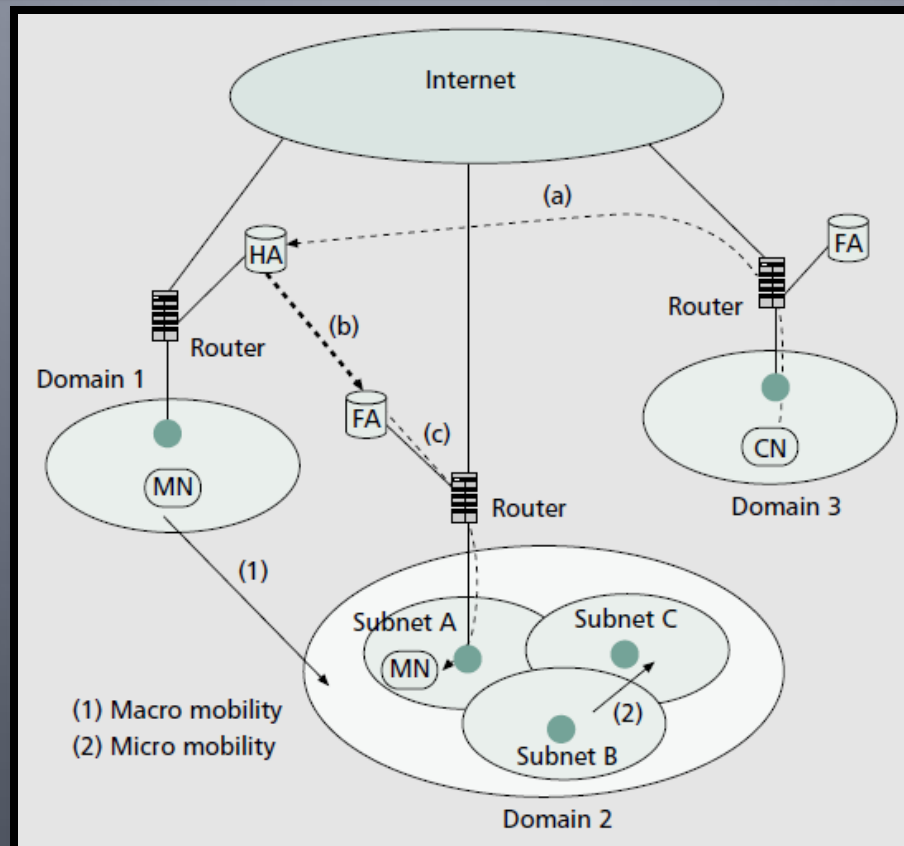

Macro Mobility Solutions

- Mobile IP
 - Utilizes a combination of Home Agent (HA), Foreign Agent (FA), and Mobile Node (MN) messaging along with Care-of-Address (CoA).
 - Previously Covered under Intranetworking.
- Handoffs occur when MN transitions to new subnet.
- Can be enhanced through the use of route optimization.

Micro Mobility Solutions

- Two main schemes:
 - Tunnel Based
 - Routing Based
- Mobile IP Regional Registration (MI-RR) / Hierarchical Mobile IP (HMIP)
 - Relies on “local Home Agents” to mask MN mobility.
 - Will Cover in Detail (HMIPv6)

Micro Mobility Solutions (cont.)

- Intra-Domain Mobility Management Protocol
 - Two level hierarchy
 - Domain
 - Subnet
 - Multiple tunnels for established to transmit packets between CN and MN.

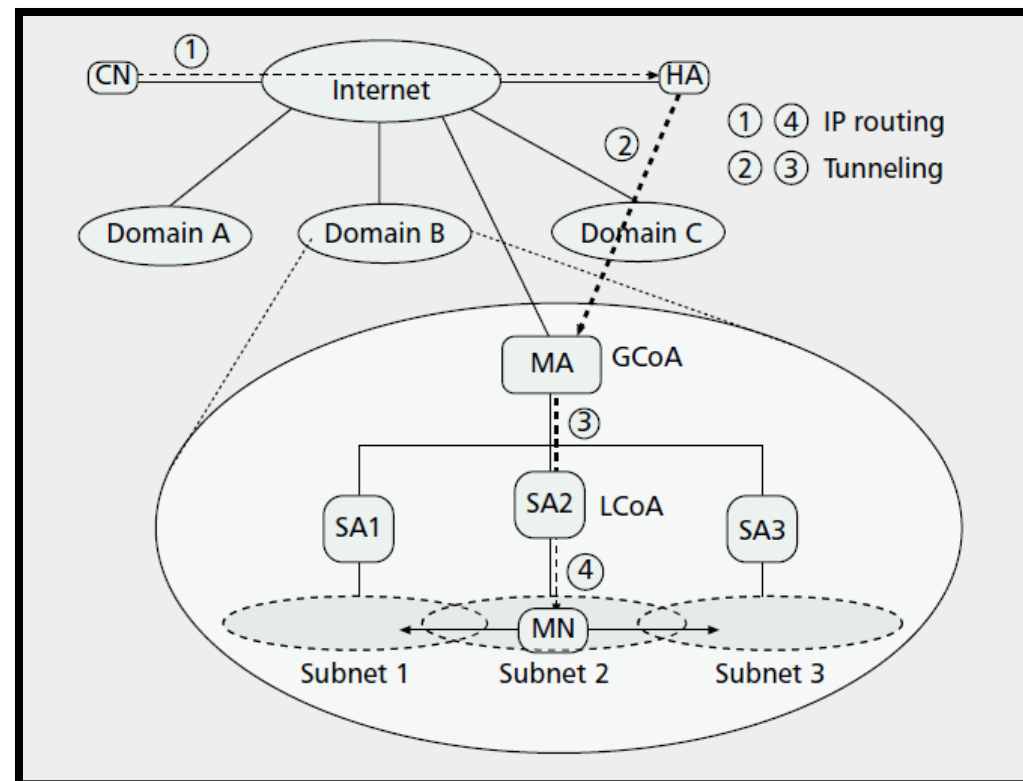

Micro Mobility Solutions (cont.)

- Cellular IP
 - Gateway-centric.
 - Handovers are automatic as MH transition BSs (subnets).
 - Utilizes distributed page caching and route caching.

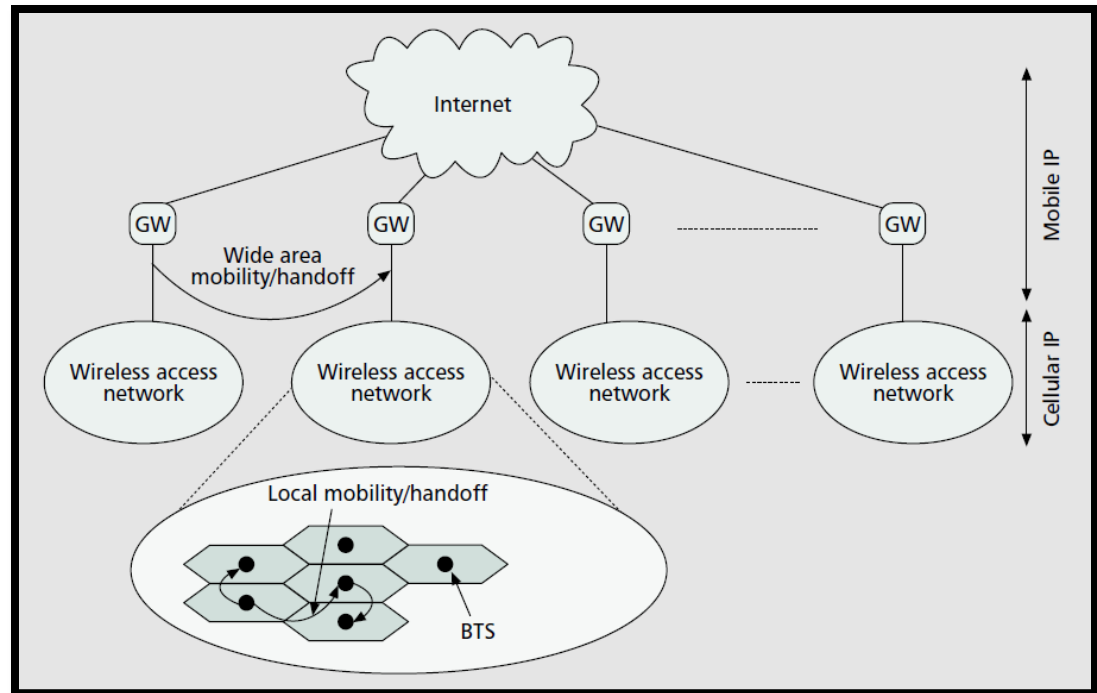

Micro Mobility Solutions (cont.)

- HAWAII
 - Domain Based.
 - Root router masks intra-domain mobility.
 - Aggregate hop-by-hop refreshes used to updates MH location info.

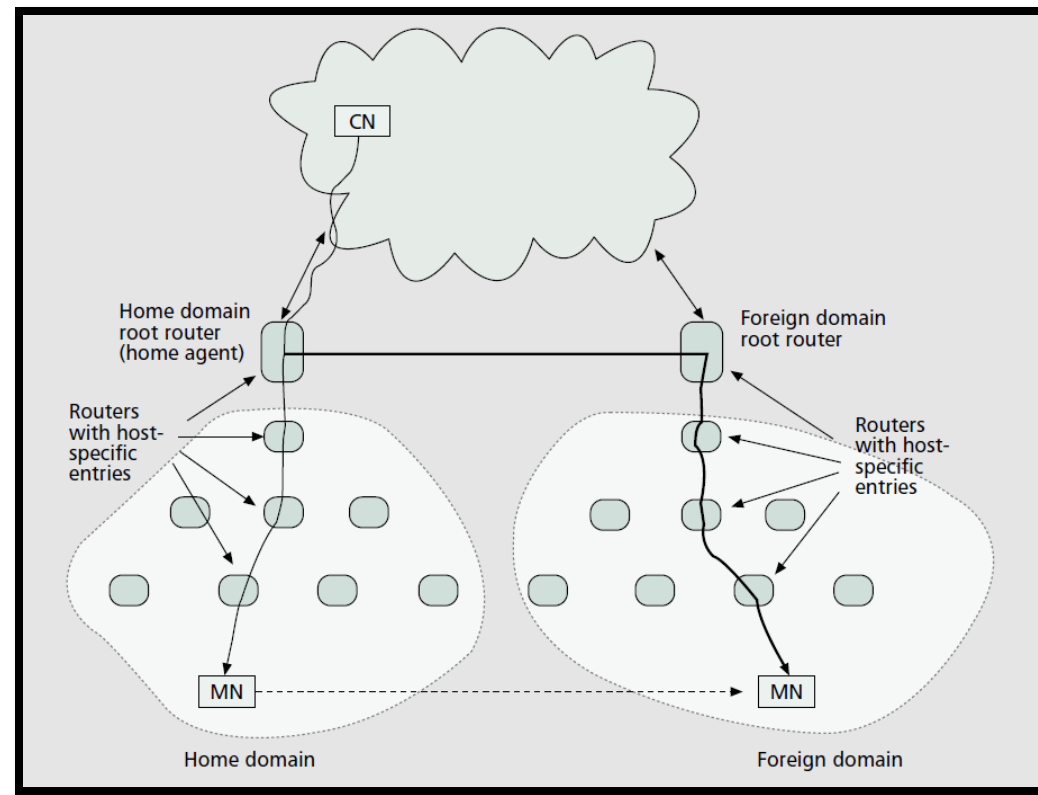

Link Layer (Layer 2) Solutions

Location & Handoff Management Research

*Intersystem Roaming is Dependent on Air Interface
Protocols and the Mobile Application Part (MAP)*

Location Management Research

- Location Management for Adjacent Networks
 - Targeting networks with overlapping areas.
 - Gateway Location Register (GLR) Protocol
 - Provides intersystem roaming
 - Gateway translates signaling between networks.
 - Shortcomings: Triangular routing

Location Management Research (cont.)

- Location Management for Adjacent Networks
 - Boundary Location Register (BLR) Protocol
 - Defined Boundary Location Area (BLA)
 - Boundary Interworking Unit (BIU) connects to the Mobile Switching Centers (MSC).
 - Translates location information, authentication, etc.
 - Handoff allows for on going communication
 - Removes triangle routing

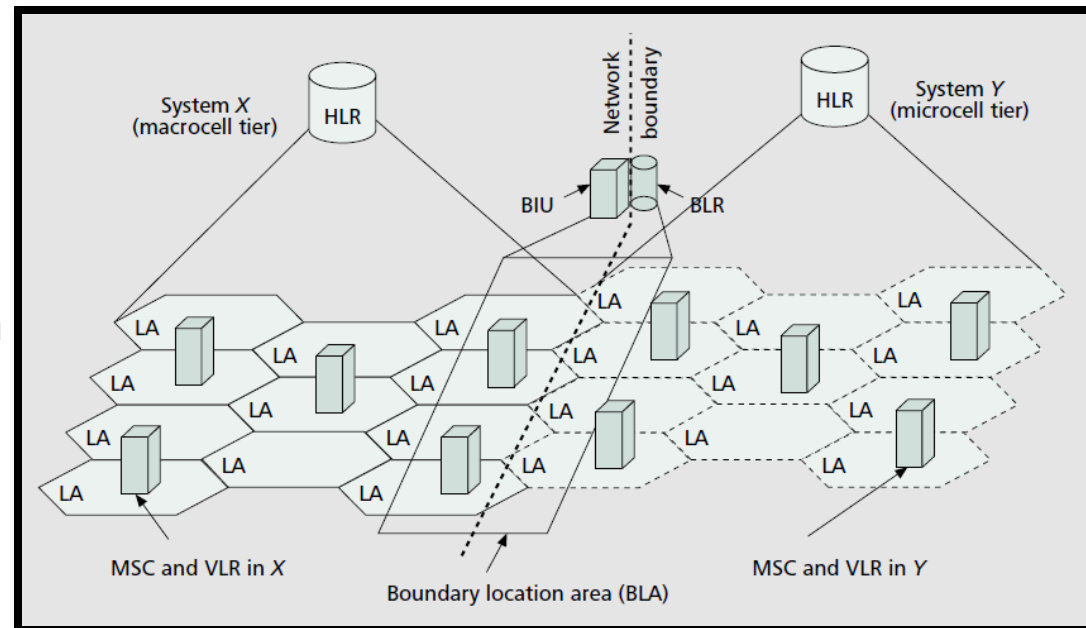

Location Management Research (cont.)

- Location Management for Overlay Networks
 - Mobile Terminals reachable via multiple networks.
 - Requires emerging of heterogeneous Home Location Registers (HLR)
 - Multi-tier HLR (MHLR)
 - Manager connects HLRs
 - Two Approaches:
 - Single Registration
 - Multiple Registration

Handoff Management Research

- Issues include:
 - Operability in networks through transformation.
 - Signal/power comparison of different interfaces.
 - Signaling between BSs and switches.
 - QoS
- UMTS/IMT-2000
 - Mobile assisted intersegment handoff
 - Can utilize boundary cells for advanced handoff warning
 - Adv. preparation for format transformation & routing between tiers, techs, networks

Handoff Management Research (cont.)

- Handoff Management in Integrated Heterogeneous Systems
 - Framework for Wireless Access Networks
 - Programmable Medium Access Control
 - Programmable Handoff
 - Vertical Handoff in Wireless Overlay
 - Handles Handoff between different wireless technologies
 - Relies on beaconing and data packets for prediction.

Cross Layer (Layer 2 + 3) Solutions

- Reduced Mobility detection delay using layer 2 information.
- Reduced handover latency.

Cross Layer (Layer 2 + 3) Solutions

- Reduced Mobility detection delay using layer 2 information.
- Reduced handover latency.
- S-MIP
 - Decision Engine (DE), scope similar to HMIP Mobile Anchor Point (MAP)
 - Utilizes link layer information to determine mobility patterns
 - Movement pattern used to determine handoffs

Cross Layer (Layer 2 + 3) Solutions (cont.)

- S-MIP scheme architecture

